



NAPCO

NAPCO SECURITY SYSTEMS, INC.
333 BAYVIEW AVENUE
AMITYVILLE, NEW YORK 11701

SALES, REPAIRS & TECHNICAL SERVICE
TOLL FREE: (800) 645-9445

INSTALLATION INSTRUCTIONS

**CF5530
COMMUNICATOR and
SUPERVISED BELL MODULE
for MA3000 and
SIGNATURE 5500-SERIES
CONTROL PANELS**

© NAPCO 1992

WI606 2/93

UL Listed: Signal System Control Unit Subassembly

GENERAL DESCRIPTION

The CF5530 is a communicator module designed for MA3000 and Signature 5500-Series Control Panels to form a Central-Station Premises Control Unit for commercial fire installations. The communicator provides supervision for Telephone No. 2, a bell and an independent bus. The module also serves as an activity monitor for the control panel; an audible alert will sound in the event that activity failure is sensed. Furthermore, since all keypads are supervised, if any keypad fails, the sounder will also cause an audible alert.

Two relays are provided for activation on trouble and/or alarm. Refer to the installation manual supplied with the control panel for programming instructions.

Refer to WI588 (MA3000) or WI635 (Signature series) for usage and wiring requirements for UL-listed systems.

SPECIFICATIONS

Power Requirements (supplied by panel): *Standby*,

12Vdc, 50mA + keypad current (see panel instructions); *Active*, 12Vdc, 90mA + keypad and bell current.

Maximum Auxiliary Output: 1.25A (dependent upon control panel loading restrictions.)

Telephone Lines: 2 supervised telephone lines provided.

Supervised Bell Output: 12Vdc, 2A max. Reports status if circuit is open or shorted.

Relay Outputs: 2 dry relays programmable (in panel) for activation on alarms or troubles.

Sounder: Indicates keypad failure or panel failure.

MOUNTING

Caution: Always remove ac and battery power before installing or removing the CF5530.

1. Remove the motherboard from the enclosure by removing the two screws that secure the heat sink to the top of the enclosure ("A" in Fig. 1) and the two screws at the bottom of the board that secure it to the cross rail ("B" in Fig. 1).

2. Mount the CF5530 module at the right side of the enclosure, off the rear wall. Position the CF5530 with the terminal strip at the bottom so that the four mounting holes align with the raised standoffs in the enclosure. Secure the module using the four self-tapping screws supplied.

3. Replace the motherboard, securing it with the screws removed in Step 1. When fully assembled, the module will be behind the motherboard but mounted low enough so that its terminal strip is exposed.

4. If a PS3000 is not required, connect the bell power leads directly to the control panel terminals: red to Fire Relay Common terminal, Terminal 6, (+); black to Terminal 16 (-). (*Do not cut Jumper F.*)

If a PS3000 is used, connect the CF5530 red lead to DC+ on the PS3000; connect the black lead to DC- on the PS3000.

ORDERING INFORMATION

EOL2.2K End-of-Line Resistor, 2200Ω

RECOMMENDED UL-LISTED DEVICES

Bells: Wheelock 46T-G4-12-R*; 46T-G6-12-R; 46T-G10-12-R; Hochiki America AL-VB-1012*; AL-MB-612*

Horns: Wheelock 34T-12-R; Faraday 6120-0-0-12-DC*; Hochiki America AL-FH-12M*

Strobe/Horns: Wheelock 7002T-12-W-FR*; 7001T-12-W-FR*; V7001-12-W-FR*

Electronic Signals: Wheelock ES-BH2-R*; ES-DL2-R*; ES-EL2-R*

Electronic Signal/Strobes: Wheelock ES-BH2-WH-12DC-HF-R*; ES-DL2-WS-12DC-VF-R*; ES-EL2-WS-12DC-HF-R*

Bell/Strobes: Wheelock 46T-G6-12-WS-12-HF-R*; 46T-G10-12-WS-12-HF-R*

*PS3000 or BDH module must be installed in the MA3000 or S5500.

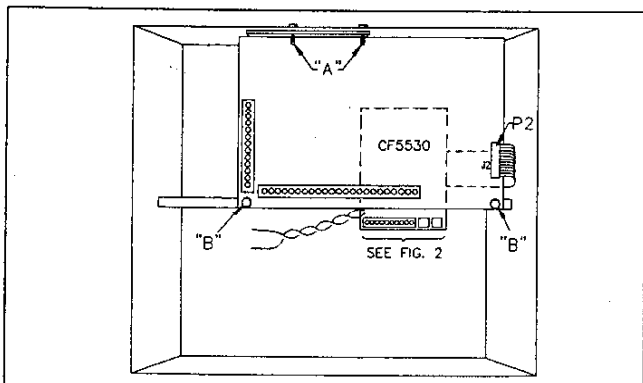

Fig 1. Location of CF5530 within H11516 enclosure.

WIRING

Signal Connections. Signal connections between the CF5530 and the control panel are made through the ribbon cable that connects to J2 on the motherboard. Refer to the *Wiring Diagram* for connections to fire keypad, bells, relays and telephone equipment.

Bell 12V Supply. Red and black wires are provided for bell power. If a PS3000 Power Supply Module is installed, connect these leads to the "DC" Terminals: red to positive

(+); black to negative (-). Refer to the instructions furnished with the control panel for system current specifications. Refer to the *Wiring Diagram* in Fig. 2 for terminal strip connections to bell, keypad, relays and telephones.

Relay 1, Relay 2. These "dry" relays can be programmed to activate on alarm or trouble (or both). Lug E3 serves as the normally-closed contact for Relay 1; Lug E4 is the normally-closed contact for Relay 2. Use Napco Part No. WL2 Harness for field wiring connection.

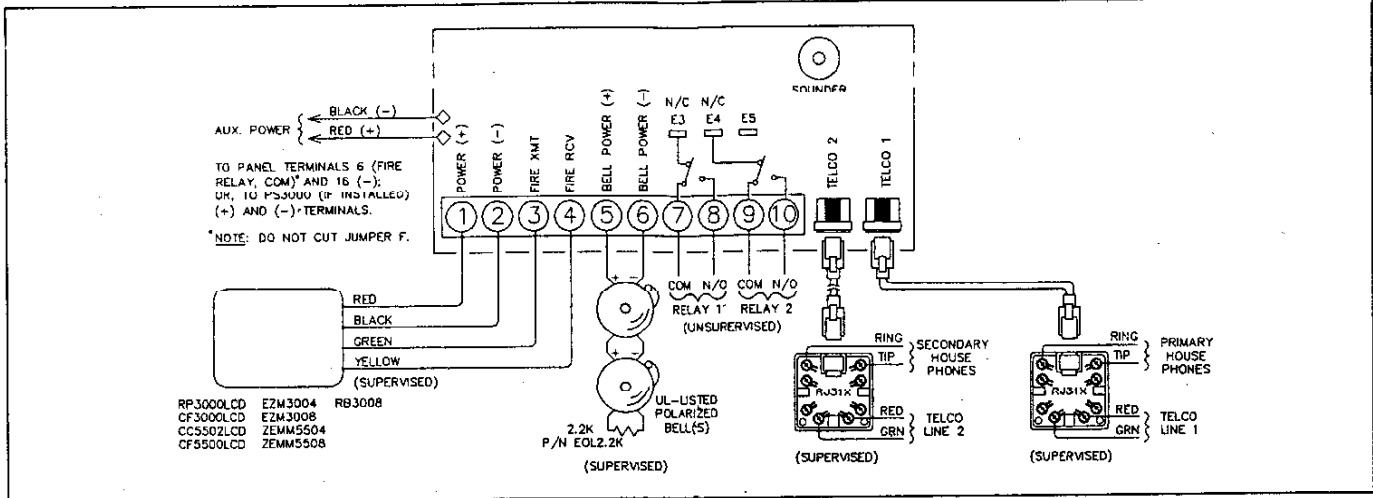

Fig. 2. Wiring Diagram.

NAPCO LIMITED WARRANTY

NAPCO SECURITY SYSTEMS, INC. (NAPCO) warrants its products to be free from manufacturing defects in materials and workmanship for fifteen months following the date of manufacture. NAPCO will, within said period, at its option, repair or replace any product failing to operate correctly without charge to the original purchaser or user.

This warranty shall not apply to any equipment, or any part thereof, which has been repaired by others, improperly installed, improperly used, abused, altered, damaged, subjected to acts of God, or on which any serial numbers have been altered, defaced or removed. Seller will not be responsible for any dismantling or reinstallation charges.

In case of defect, contact the security professional who installed and maintains your security system. NAPCO shall have no obligation under this warranty, or otherwise, if the product has been repaired by others, improperly installed, improperly used, abused, altered, damaged, subjected to accident, nuisance, flood, fire or acts of God, or on which any serial numbers have been altered, defaced or removed. NAPCO will not be responsible for any dismantling, reassembly or reinstallation charges.

In order to exercise the warranty, the product must be returned by the user or purchaser, shipping costs prepaid and insured to NAPCO. After repair or replacement, NAPCO assumes the cost of returning products under warranty.

There are no warranties, express or implied, which extend beyond the description on the face hereof. There is no express or implied warranty of merchantability or a warranty of fitness for a particular purpose. Additionally, this warranty is in lieu of all other obligations or liabilities on the part of NAPCO.

Any action for breach of warranty, including but not limited to any implied warranty of merchantability, must be brought within the six months following the end of the warranty period. In no case shall NAPCO be liable to anyone for any consequential or incidental damages for breach of this or any other warranty, express or implied, even if the loss or damage is caused by the seller's own negligence or fault.

This warranty contains the entire warranty. It is the sole warranty and any prior agreements or representations, whether oral or written, are either merged herein or are expressly cancelled. NAPCO neither assumes, nor authorizes any other person purporting to act on its behalf to modify, to change, or to assume for it, any other warranty or liability concerning its products.

In no event shall NAPCO be liable for an amount in excess of NAPCO's original selling price of the product, for any loss or damage, whether

direct, indirect, incidental, consequential, or otherwise arising out of any failure of the product. Seller's warranty, as hereinabove set forth, shall not be enlarged, diminished or affected by and no obligation or liability shall arise or grow out of Seller's rendering of technical advice or service in connection with Buyer's order of the goods furnished hereunder.

NAPCO RECOMMENDS THAT THE ENTIRE SYSTEM BE COMPLETELY TESTED WEEKLY.

Warning: Despite frequent testing, and due to, but not limited to, any or all of the following; criminal tampering, electrical or communications disruption, it is possible for the system to fail to perform as expected. NAPCO does not represent that the product/system may not be compromised or circumvented; or that the product or system will prevent any personal injury or property loss by burglary, robbery, fire or otherwise; nor that the product or system will in all cases provide adequate warning or protection. A properly installed and maintained alarm may only reduce risk of burglary, robbery, fire or otherwise but it is not insurance or a guarantee that these events will not occur. **CONSEQUENTLY, SELLER SHALL HAVE NO LIABILITY FOR ANY PERSONAL INJURY, PROPERTY DAMAGE, OR OTHER LOSS BASED ON A CLAIM THE PRODUCT FAILED TO GIVE WARNING.** Therefore, the installer should in turn advise the consumer to take any and all precautions for his or her safety including, but not limited to, fleeing the premises and calling police or fire department, in order to mitigate the possibilities of harm and/or damage.

NAPCO is not an insurer of either the property or safety of the user's family or employees, and limits its liability for any loss or damage including incidental or consequential damages to NAPCO's original selling price of the product regardless of the cause of such loss or damage. If the user wishes to protect itself to a greater extent, NAPCO will, at user's sole cost and expense, obtain an insurance policy to protect the user, supplemental to user's own policy, at a premium to be determined by NAPCO's insurer upon written notice from user by Certified Mail, Return Receipt Requested, to NAPCO's home office address, and upon payment of the annual premium cost by user.

Some states do not allow limitations on how long an implied Warranty lasts or do not allow the exclusion or limitation of incidental or consequential damages, or differentiate in their treatment of limitations of liability for ordinary or gross negligence, so the above limitations or exclusions may not apply to you. This Warranty gives you specific legal rights and you may also have other rights which vary from state to state.